



APPLICATION EXAMPLES USING EDM MODAL Year 2021

December 2021

© Crystal Instruments Corporation

by Aakash Umesh Mange – Application Engineer
www.crystalinstruments.com | info@go-ci.com

Table of Contents

Year 2021: Application Examples Using EDM Modal	2
Modal Analysis of Pole Generator.....	2
Ground Vibration Test	3
Modal Analysis of Train Wheel.....	4
Modal Analysis of Robot	5
Operational Modal Analysis of Building.....	6
Modal Survey of Floors	7
Modal Survey of Engines.....	8
Modal Analysis of Stuffed Printed Circuit Boards	9
Modal Analysis of Smart Speakers.....	10
Modal Analysis of Brake Discs	11
Modal Analysis of Propellers.....	12
Modal Analysis of Satellite.....	13
Modal Analysis of Factory Machinery	14
Modal Analysis of Actuator.....	15
Modal Analysis of Cooling System	16
Modal Analysis of Train Brake Disc	17
Modal Analysis of Head Light Assembly.....	18
Modal Analysis of Locomotive Wheel.....	19
Modal Analysis of Machinery	20
Modal Analysis of Gun Barrel Parts.....	21
Modal Analysis of Car Wheel.....	22
Modal Analysis of Shaker Head Expander.....	23
Modal Analysis of Gantry Crane	24
Modal Analysis of MRI Carrier	25
Modal Analysis of Baseball Bat	26
Modal Analysis of Processing Equipment.....	27
Modal Analysis of Road Pavements	28
Modal Analysis of Rain Drop Sensor Assembly	29
Modal Analysis of Academic Structures in Universities.....	30

Year 2021: Application Examples Using EDM Modal

Illustrated below are some customer applications in varying industries who are using the hardware and software by Crystal Instruments to analyze and understand the structural properties of their test specimen(s). Analyzing the modal characteristics namely natural frequencies, damping and mode shapes of the test unit further helps in improving the design to enhance the mechanical behavior of the test unit.



Modal Analysis of Pole Generator

This customer in UK executes modal analysis using CoCo80X and EDM Modal to ensure that the natural frequencies are not close to the forcing frequencies of their pole turbo generator.

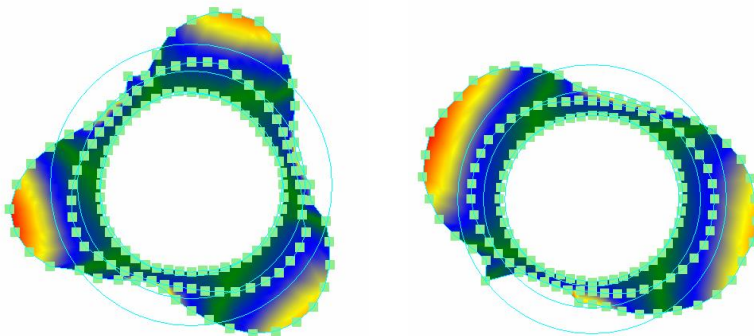

Ground Vibration Test

A customer is using Spider-80M and EDM Modal for their ground vibration test which is not only used to validate analytical models but also used to predict the flutter of the aircraft in order to create a safe flight envelope before the flight operates.



Perspective



Modal Analysis of Train Wheel

This overseas customer is executing modal analysis using Spider 80Xi and EDM Modal to understand the dynamics of wheel-rail interactions. During the ride or brake operation of a train, there could be certain excitation frequencies which could cause the resonance phenomenon and potentially affect the safety and comfort of passengers.

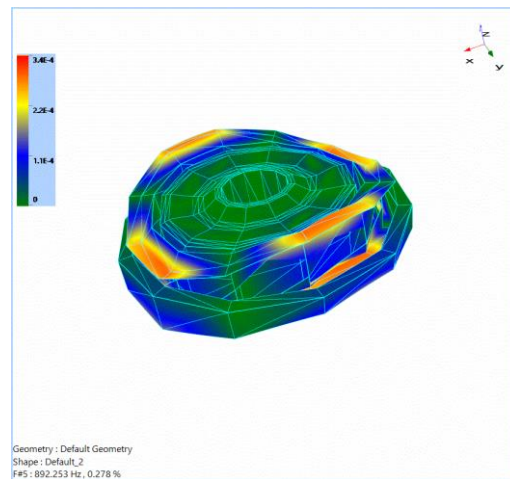
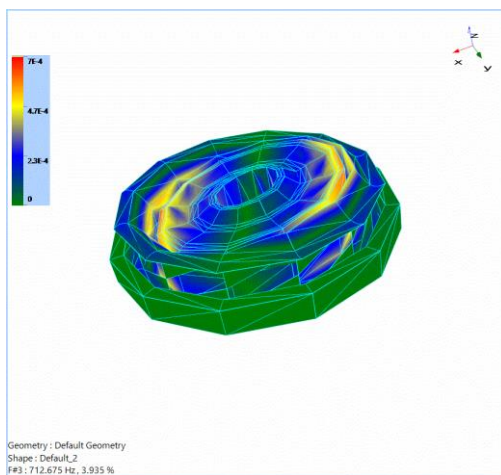

Modal Analysis of Robot

This customer participates in robot combat competitions called BattleBots and is using Spider80X and EDM Modal to understand the structural properties of the blades. This modal survey helps in optimizing the design of the robot for improving the mechanical behavior during each of the battles.

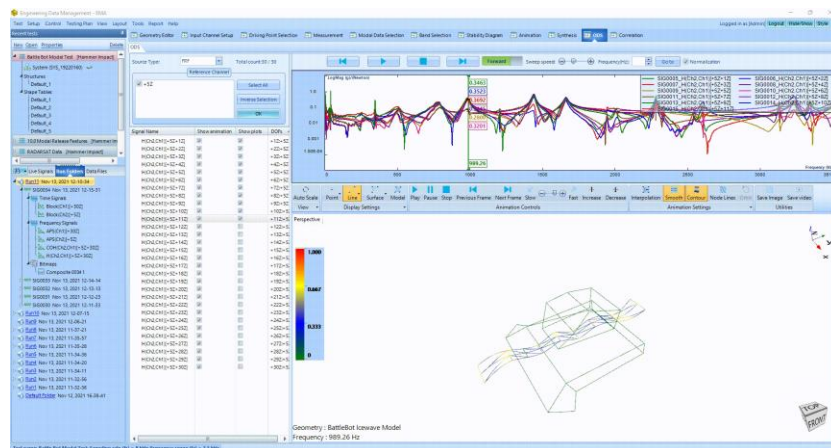
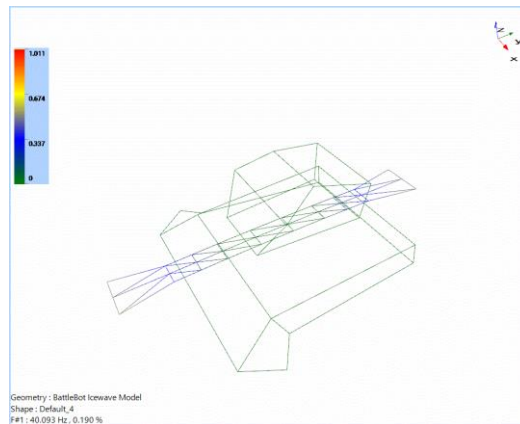

Operational Modal Analysis of Building

This Canadian customer is executing operational modal analysis using Crystal Instruments to ensure that their buildings pass the necessary standards.

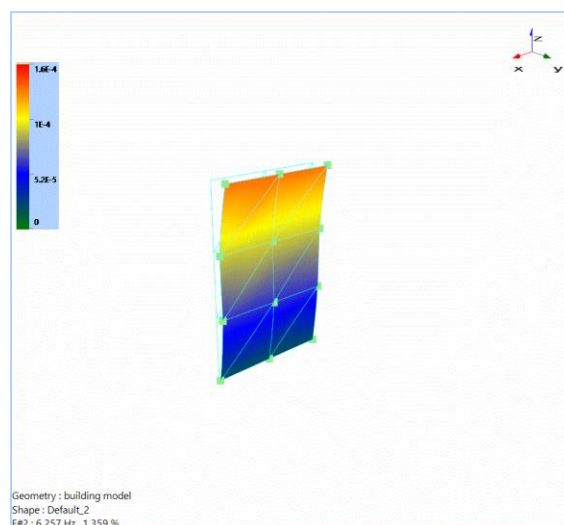
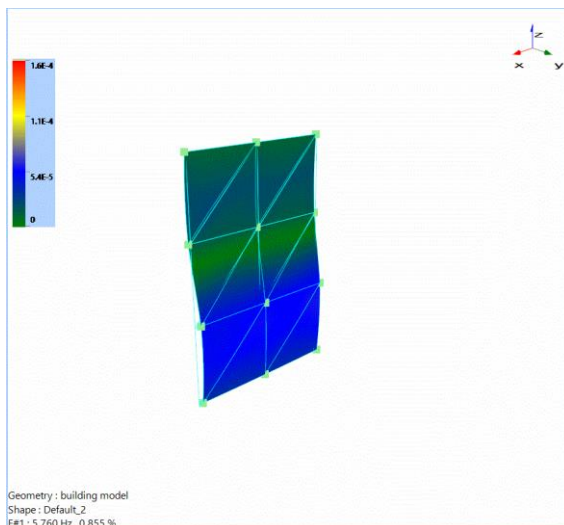
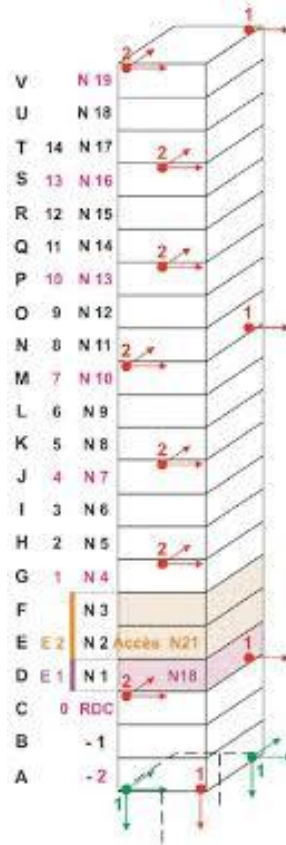

Modal Survey of Floors

This US customer in the east coast is using a CoCo-80X to study the floor vibrations of a building to better understand the structural properties.



Modal Survey of Engines

An automotive company is using EDM Modal to ensure none of the natural frequencies lie within the operating Engine RPM.

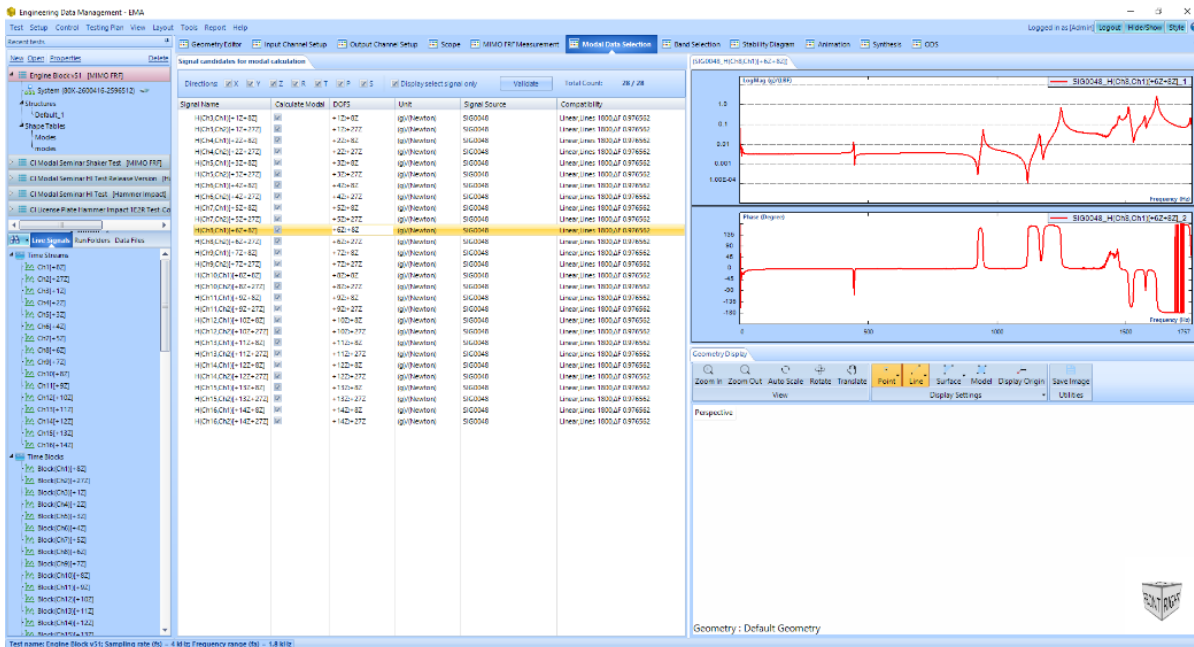

Modal Analysis of Stuffed Printed Circuit Boards

A semiconductor chip manufacturer in the bay area of California is using a Spider80X and EDM Modal to ensure that the stuffed board with capacitors and other components does not have any resonances in the desirable frequency range as it can have an undesirable effect on the device in which it is installed.

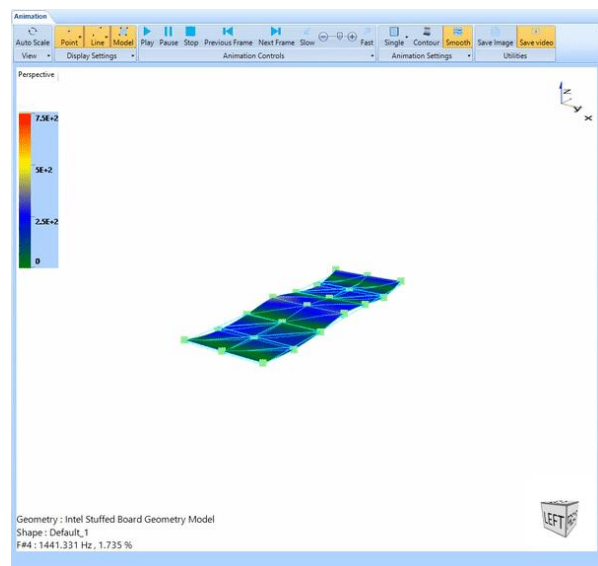
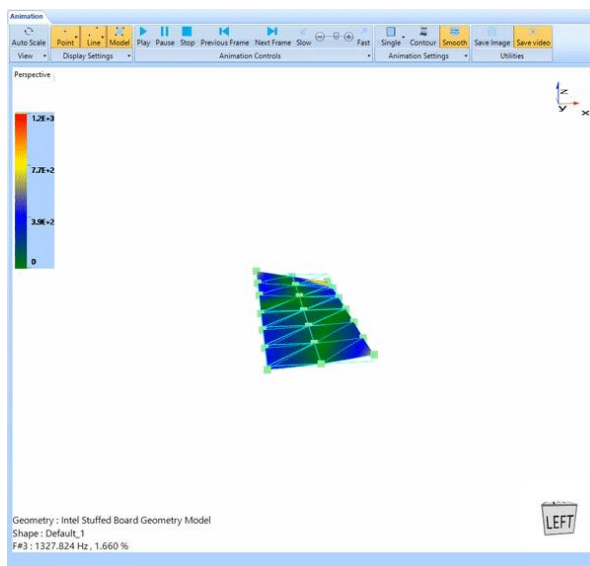

Modal Analysis of Smart Speakers

A big company in Silicon Valley that specializes in software, hardware, search engine is using Spider-80X and EDM Modal for modal analysis of their smart speakers.

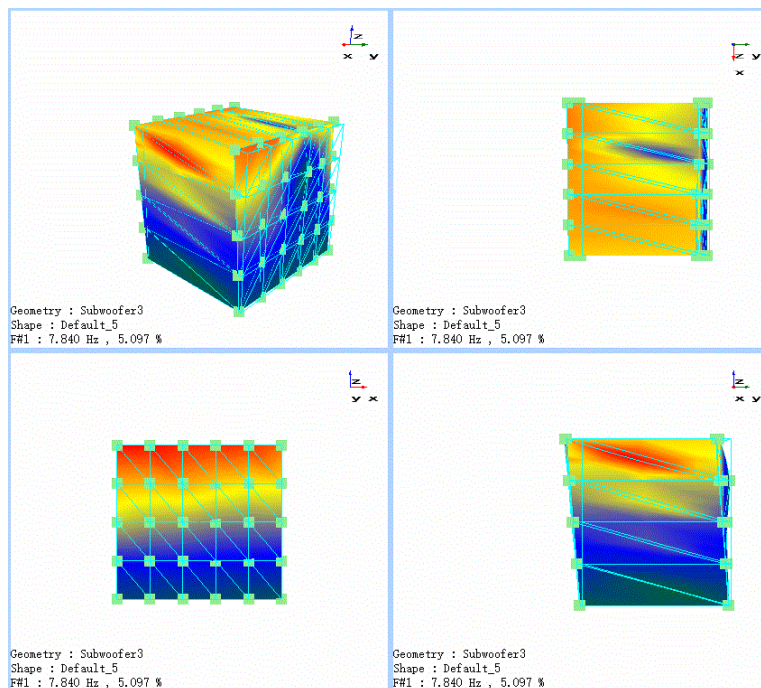

Modal Analysis of Brake Discs

A brake manufacturer is using Spider80X and EDM Modal to ensure that the natural frequencies of their disc brake rotor are not close to one of the excitation frequencies during braking. A brake squeal could introduce a lot of unpleasant vibration and noise.

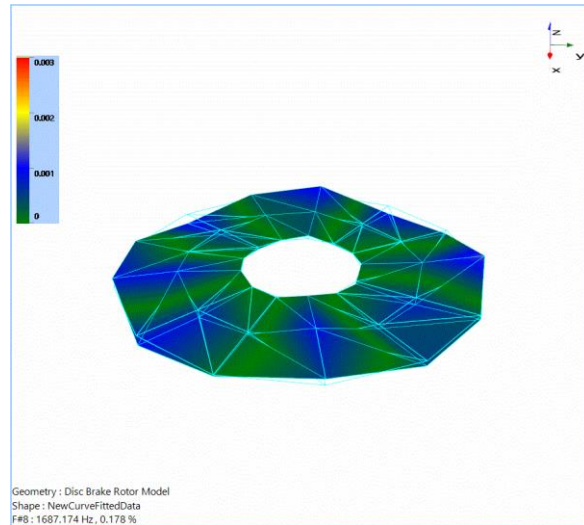
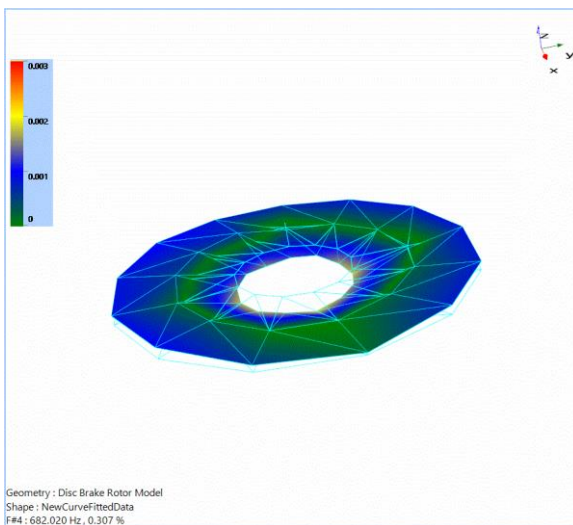
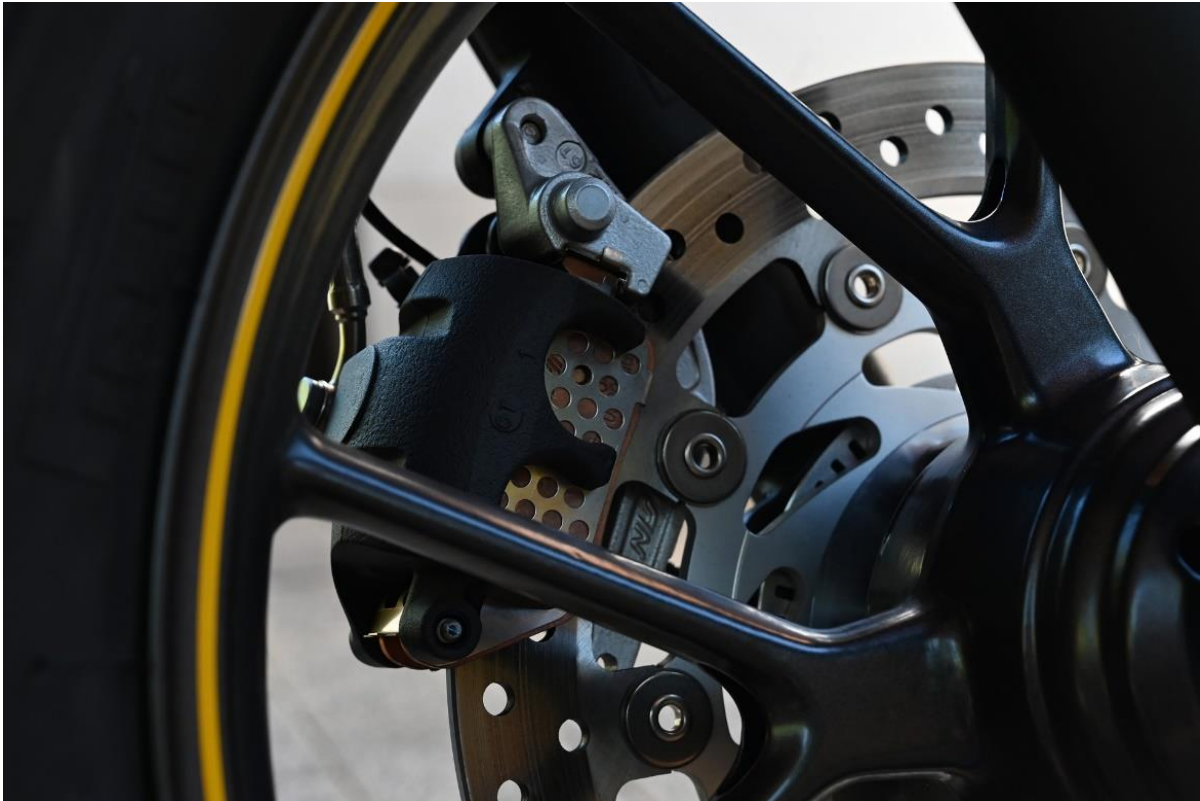

Modal Analysis of Propellers

A customer is using Crystal Instruments system for modal testing and analysis of their aircraft propeller.

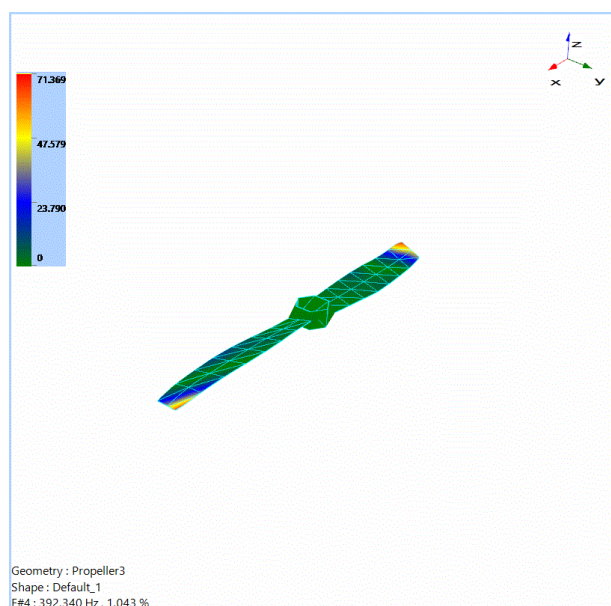
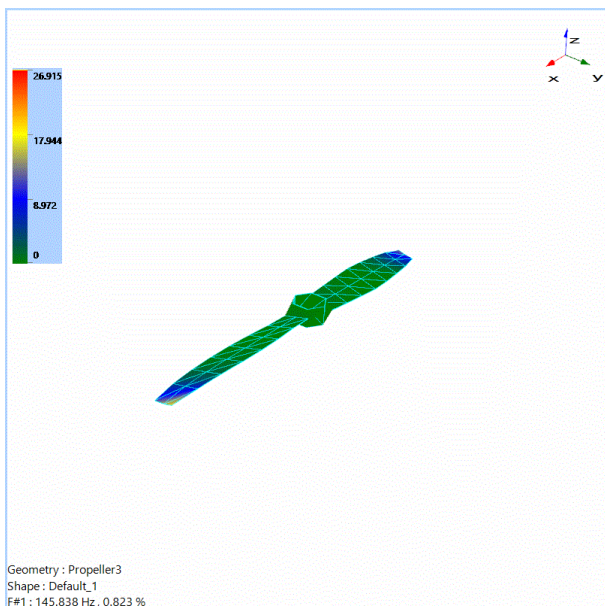

Modal Analysis of Satellite

One of our customers is using Crystal Instruments hardware system along with EDM Modal to execute modal testing and analysis on their satellites.

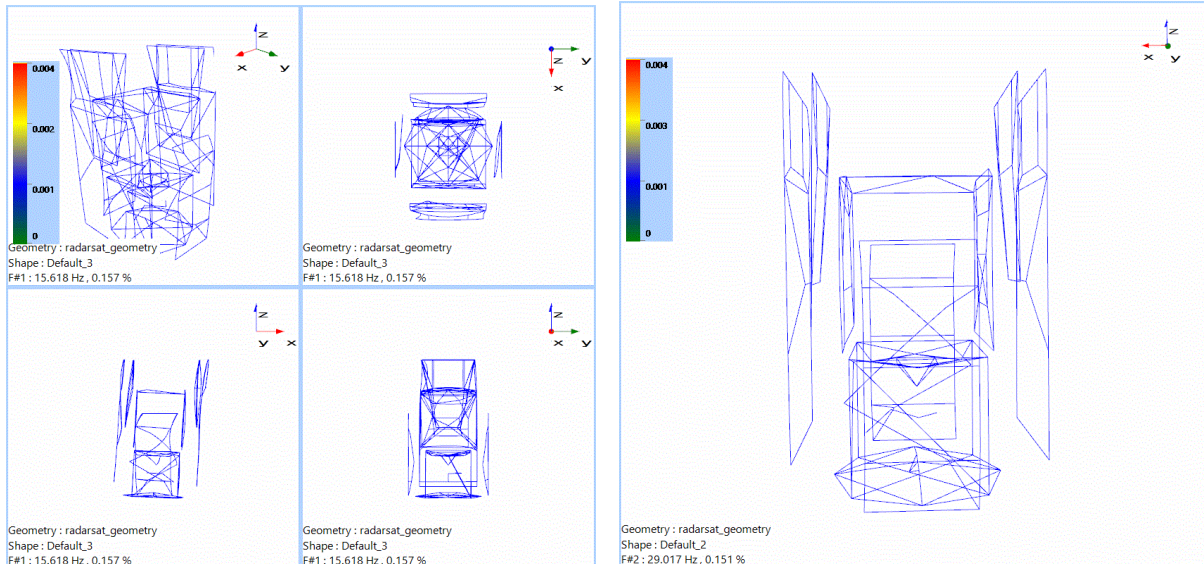
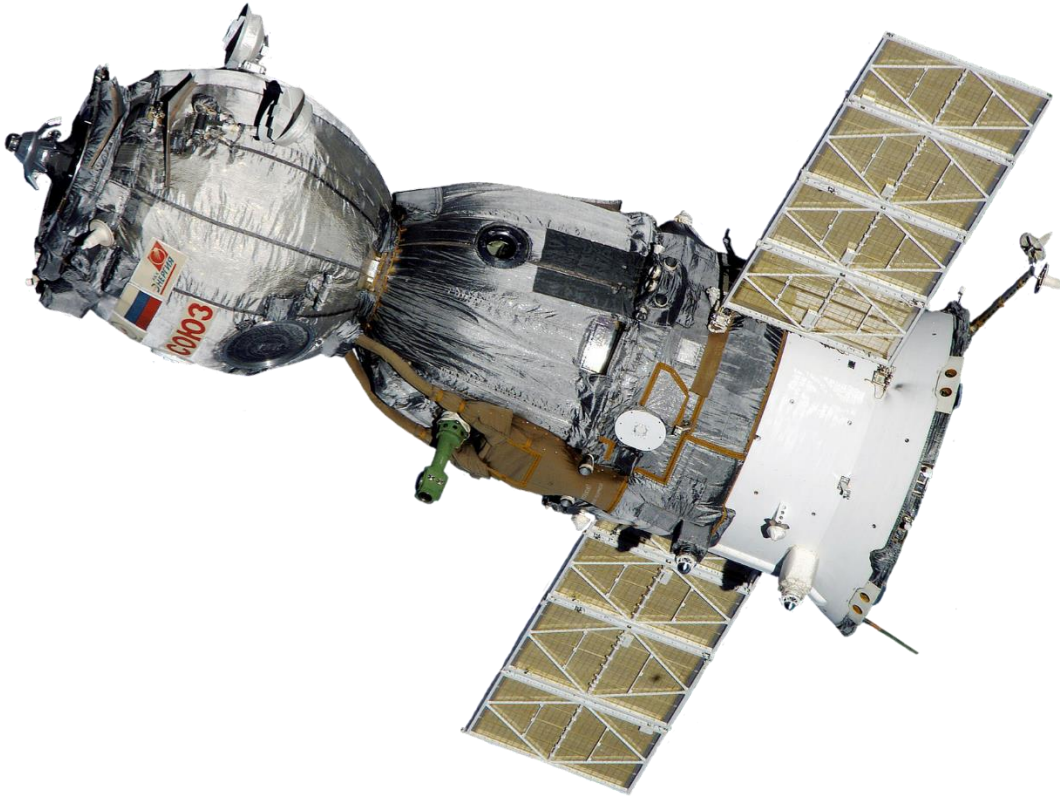

Modal Analysis of Factory Machinery

A customer in UK is using CoCo-80 and EDM Modal from Crystal Instruments to perform modal analysis of their factory machinery.

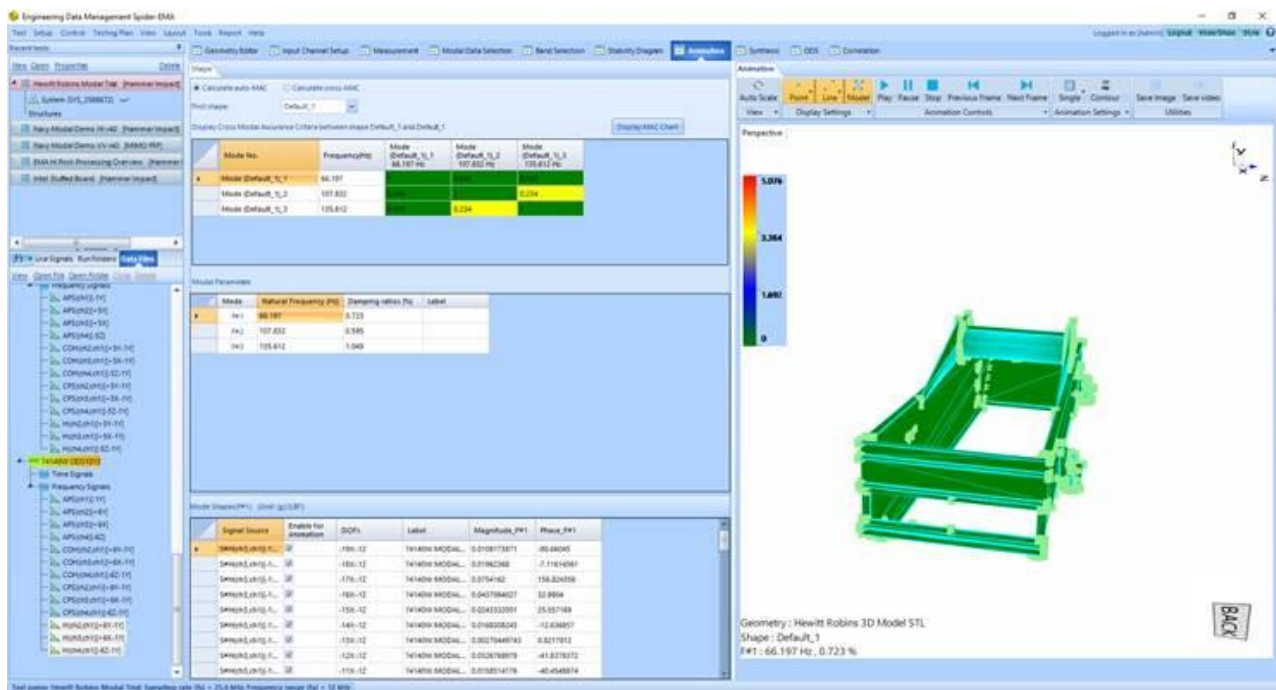

Modal Analysis of Actuator

Another US east coast customer is using Crystal Instruments' Modal package for obtaining FRFs of their actuator.

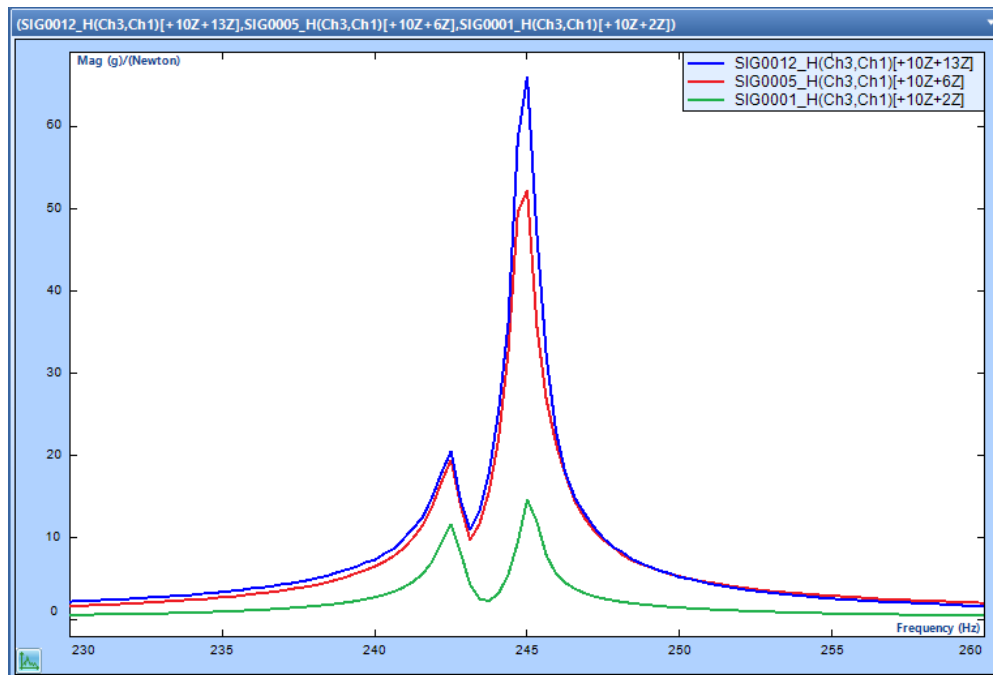

Modal Analysis of Cooling System

An overseas customer is using Spider 80X and EDM Modal to execute modal analysis of their cooling system.

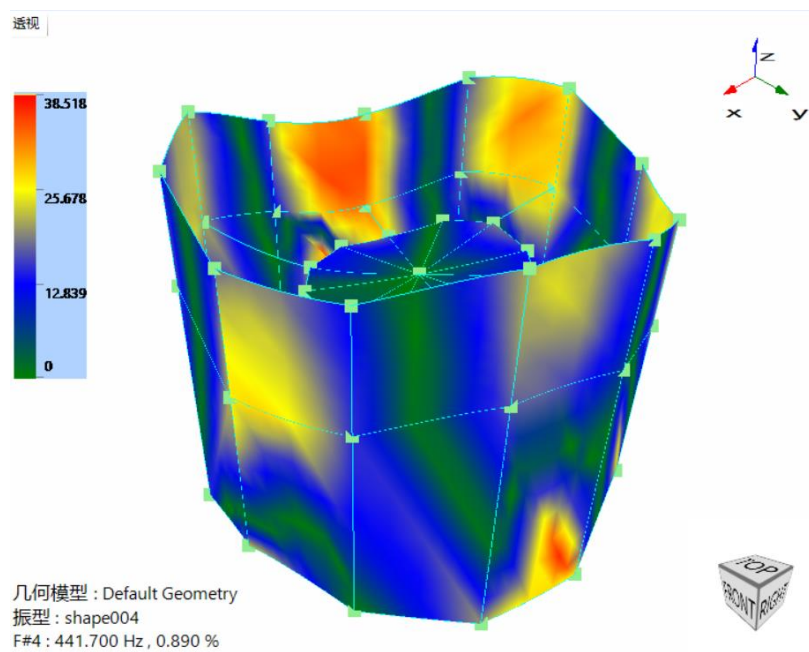
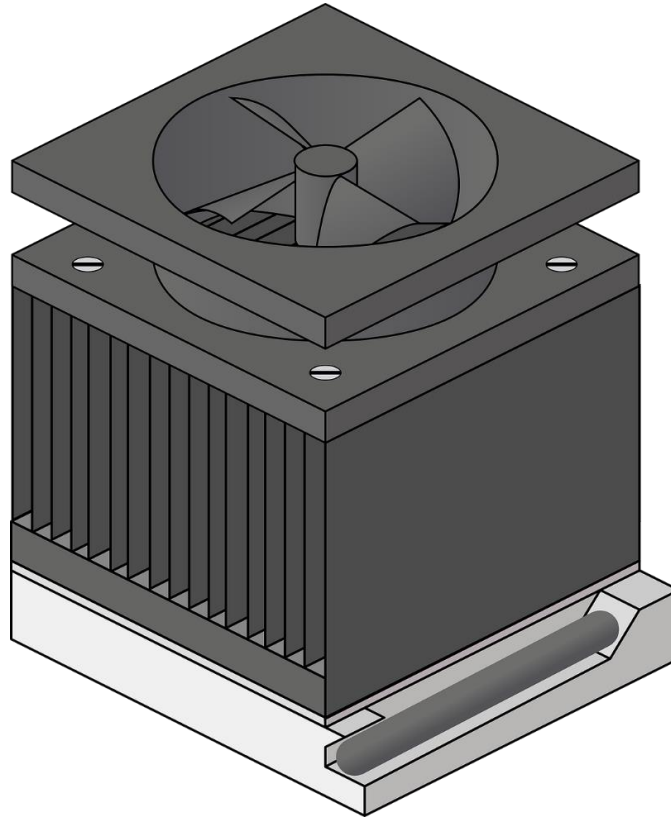

Modal Analysis of Train Brake Disc

Another international customer is using Crystal Instruments' Modal package for executing modal analysis of their train brake disc.

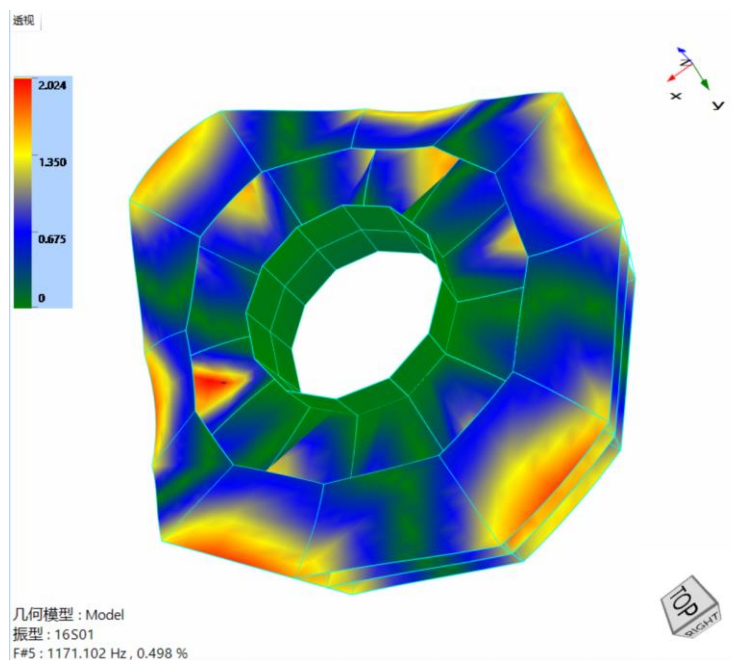
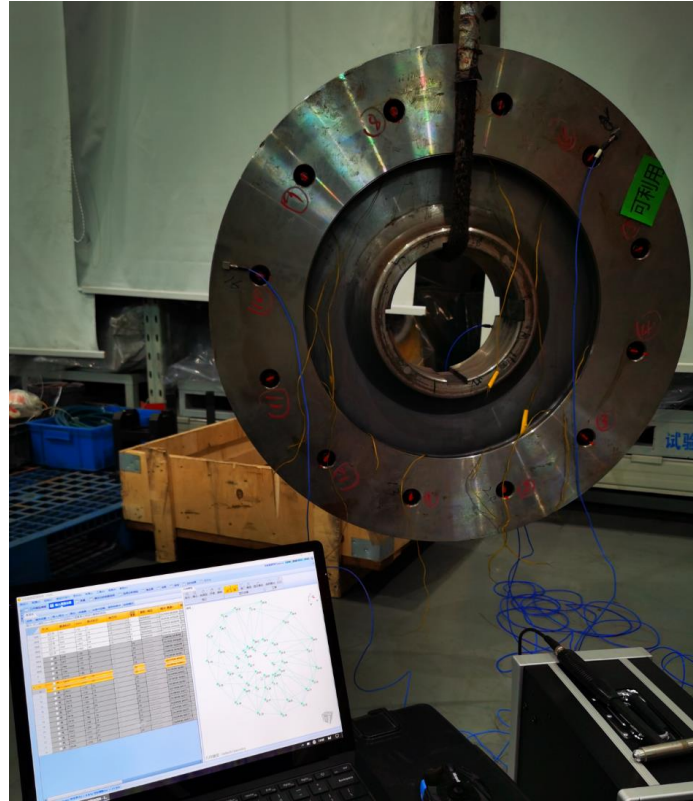

Modal Analysis of Head Light Assembly

An automotive customer is using Crystal Instrument's EDM Modal and hardware system to carry out modal testing and analysis of their headlight system assembly.

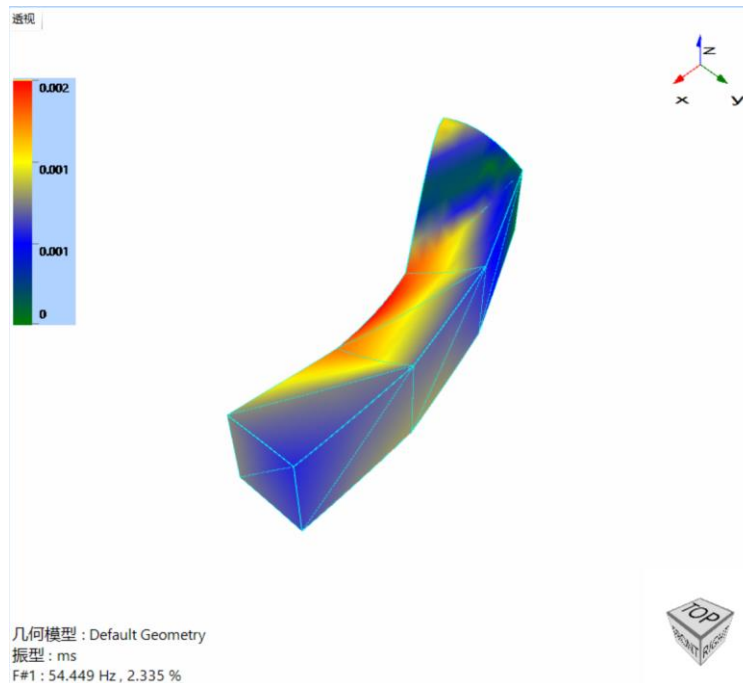

Modal Analysis of Locomotive Wheel

An international customer is using Crystal Instruments' Modal package for modal testing and analysis of their locomotive wheel.

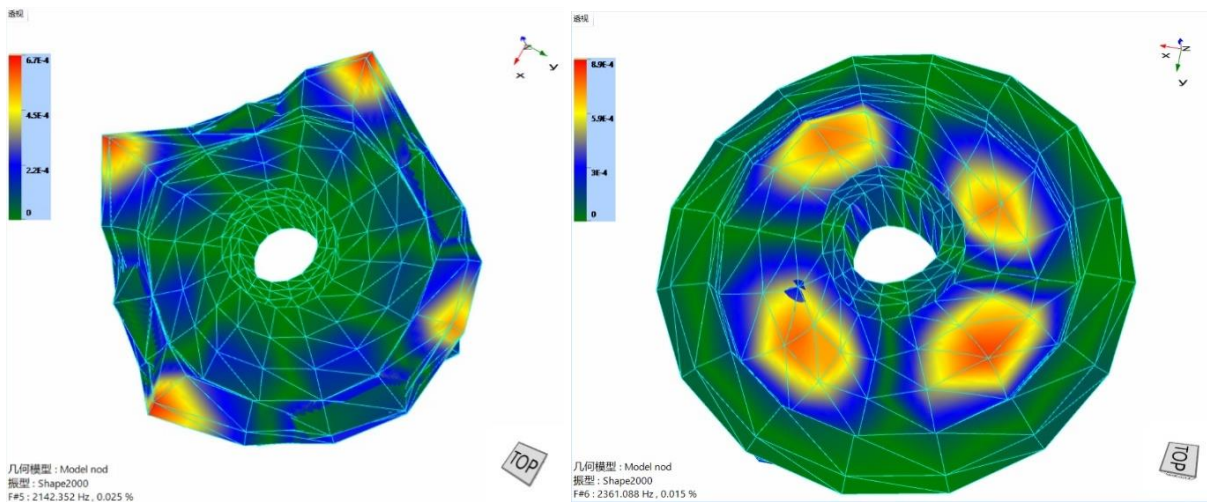
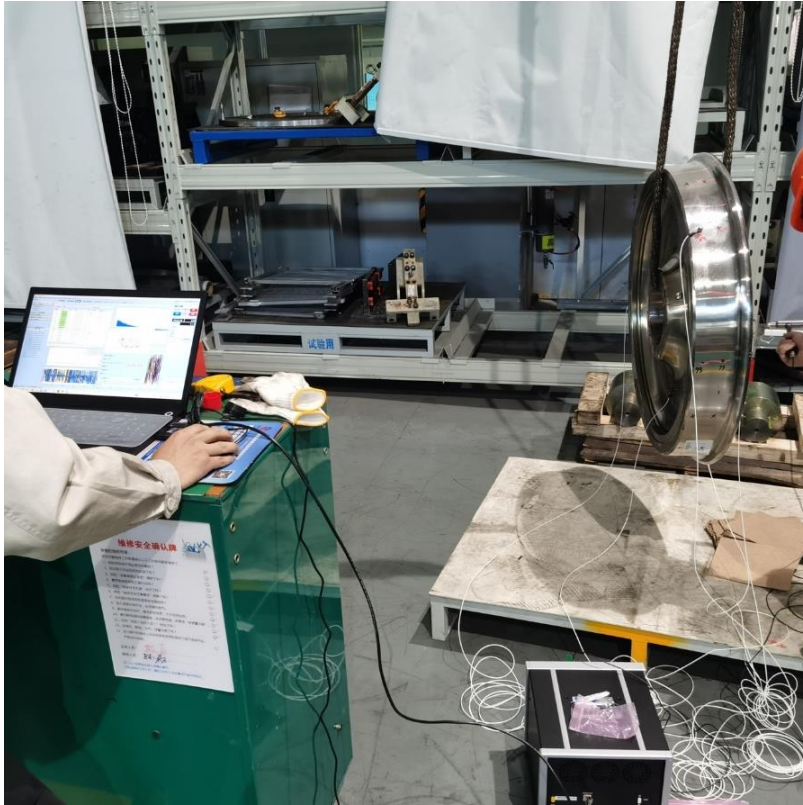

Modal Analysis of Machinery

Another international customer is using CoCo80X and EDM Modal for modal testing and analysis of their machinery.

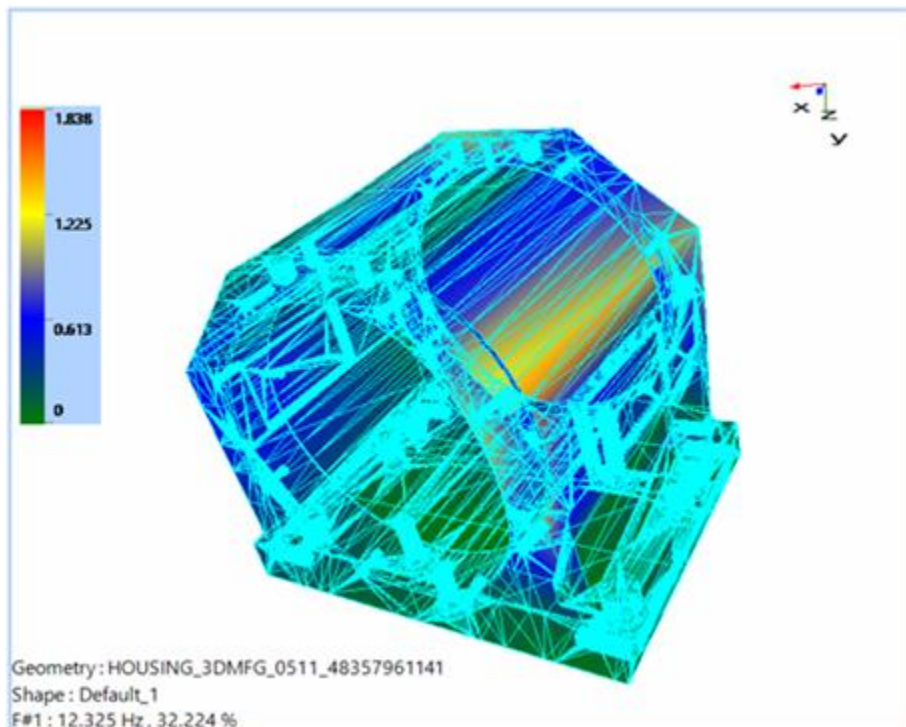

Modal Analysis of Gun Barrel Parts

A US east coast customer is using EDM Modal to qualify raw materials for their gun barrels.

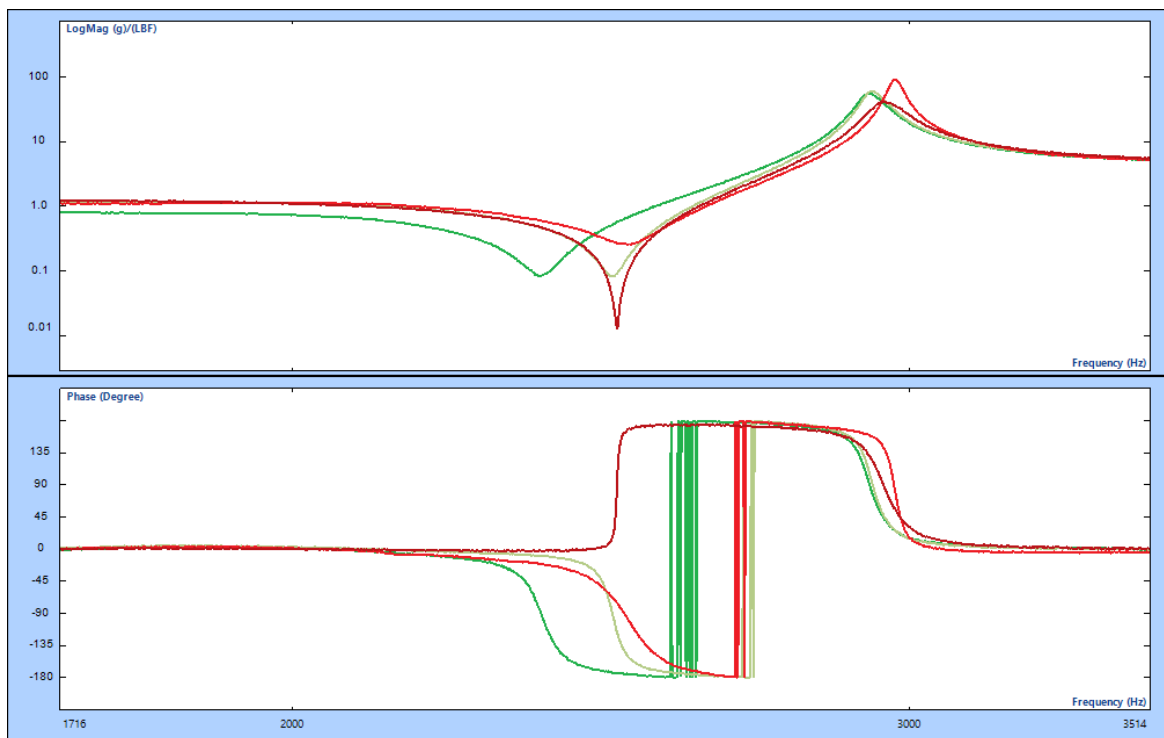

Modal Analysis of Car Wheel

Another customer in Southern California is using Crystal Instrument's Modal solution package for acquiring FRFs of their automotive wheels.

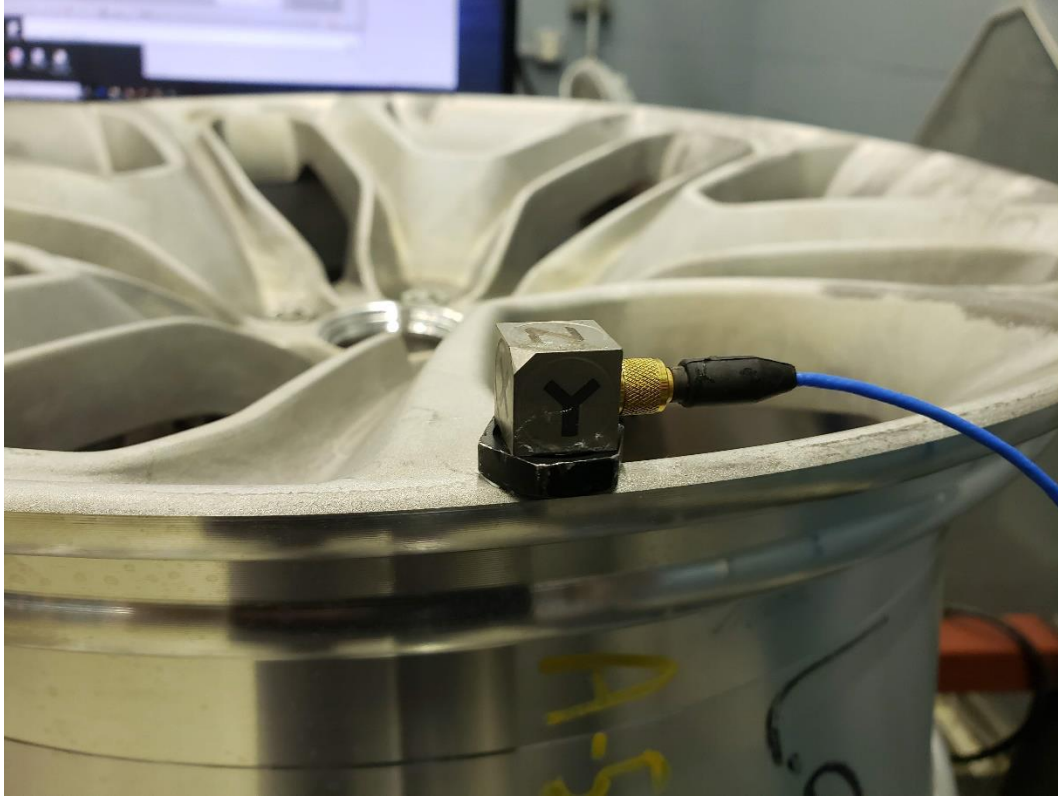

Modal Analysis of Shaker Head Expander

Another customer who actually uses our vibration controller is executing modal analysis of their head expander to ensure that the modes do not lie within the desired frequency range.

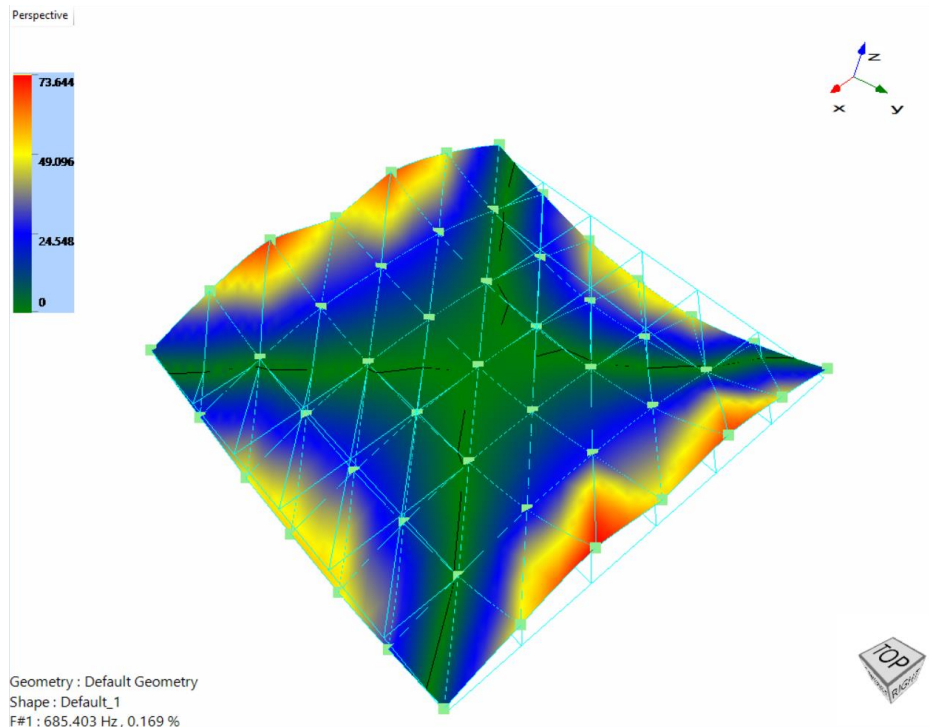

Modal Analysis of Gantry Crane

Another customer in the east coast of US is using Crystal Instruments' Modal package for measuring and analyzing the resonances of their gantry crane.

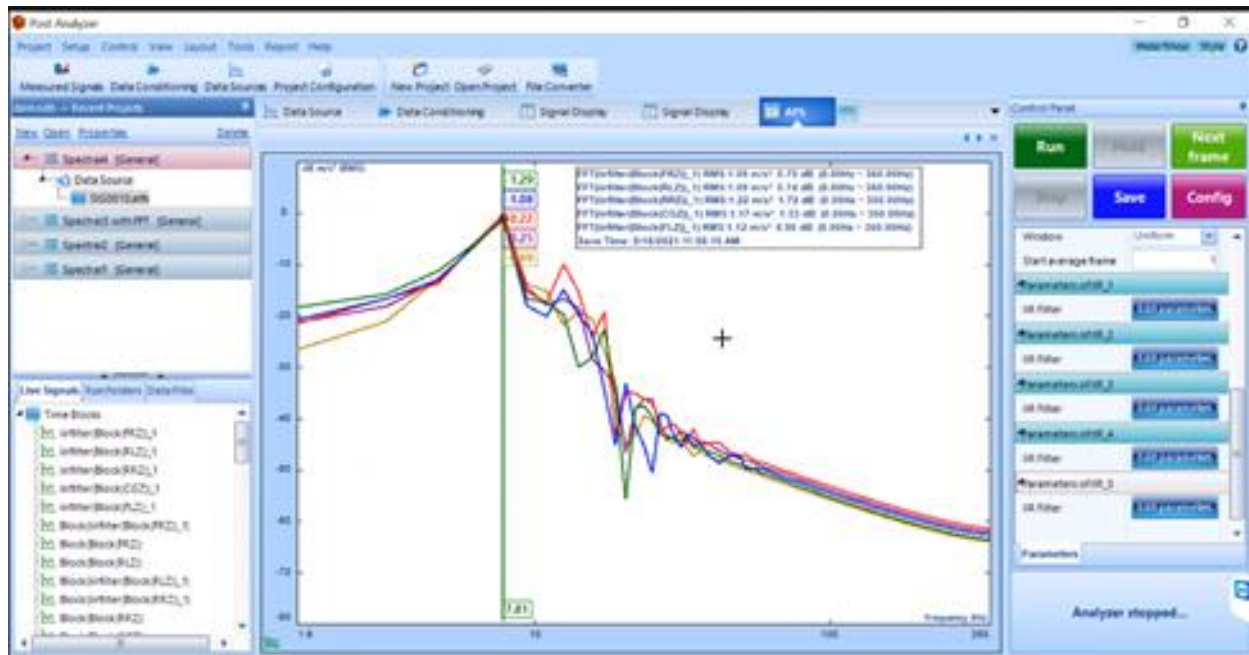
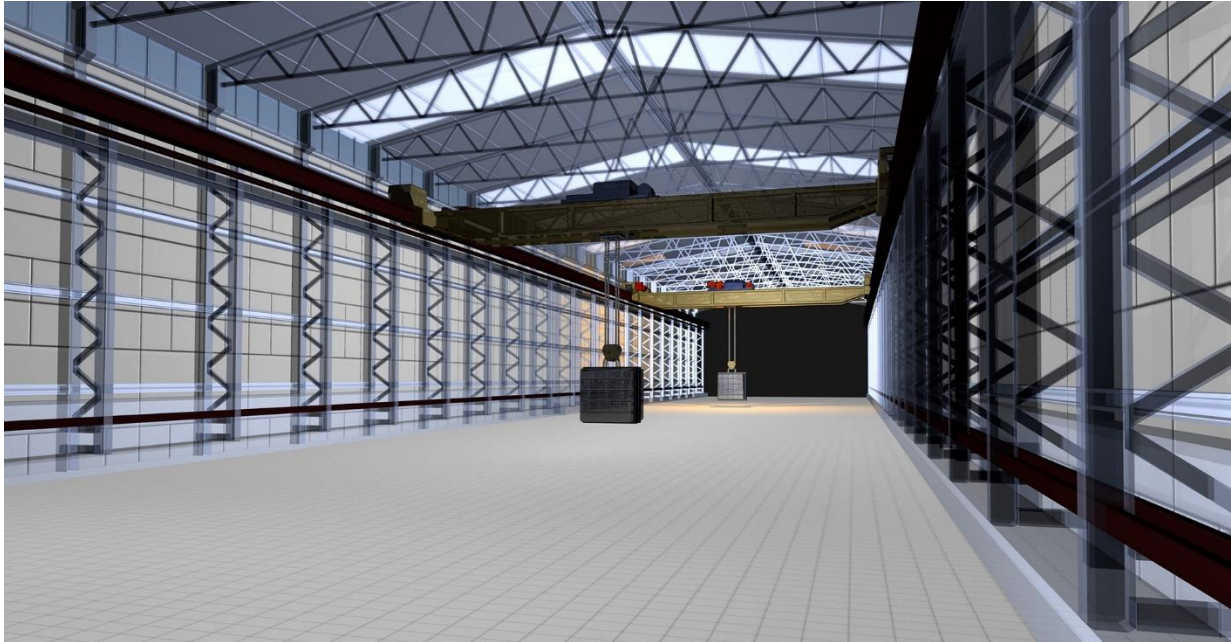

Modal Analysis of MRI Carrier

Another customer of ours is using Crystal Instruments' Modal package for measuring and analyzing the resonances of the carrier in MRI machine to help identify weak links.

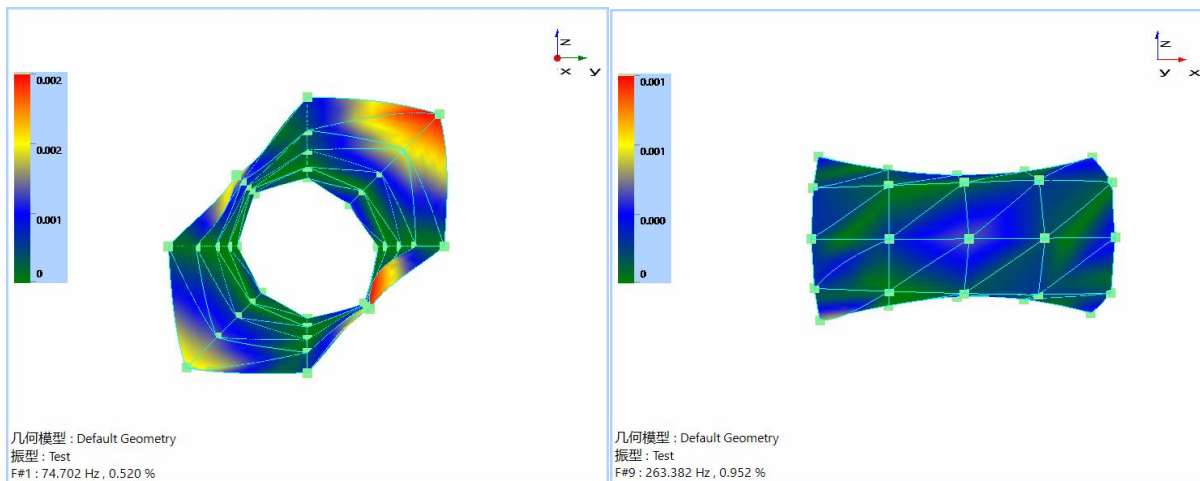
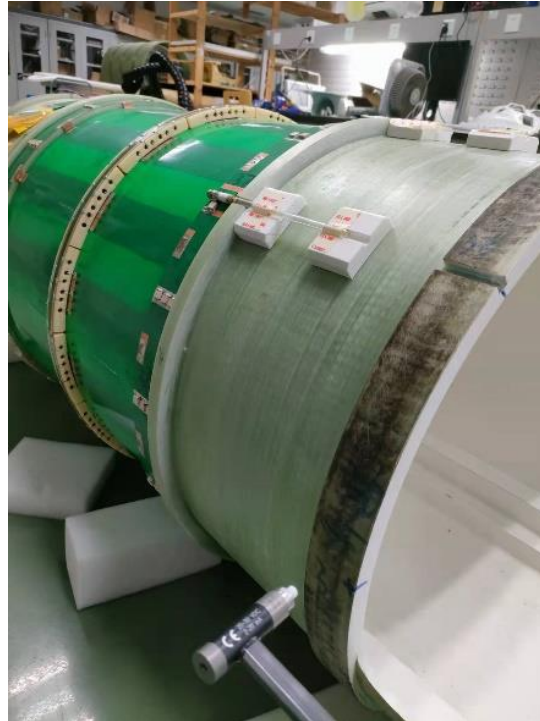

Modal Analysis of Baseball Bat

Another US customer is using Crystal Instruments' Spider80X and EDM Modal for identifying the sweet spot of their baseball bats.

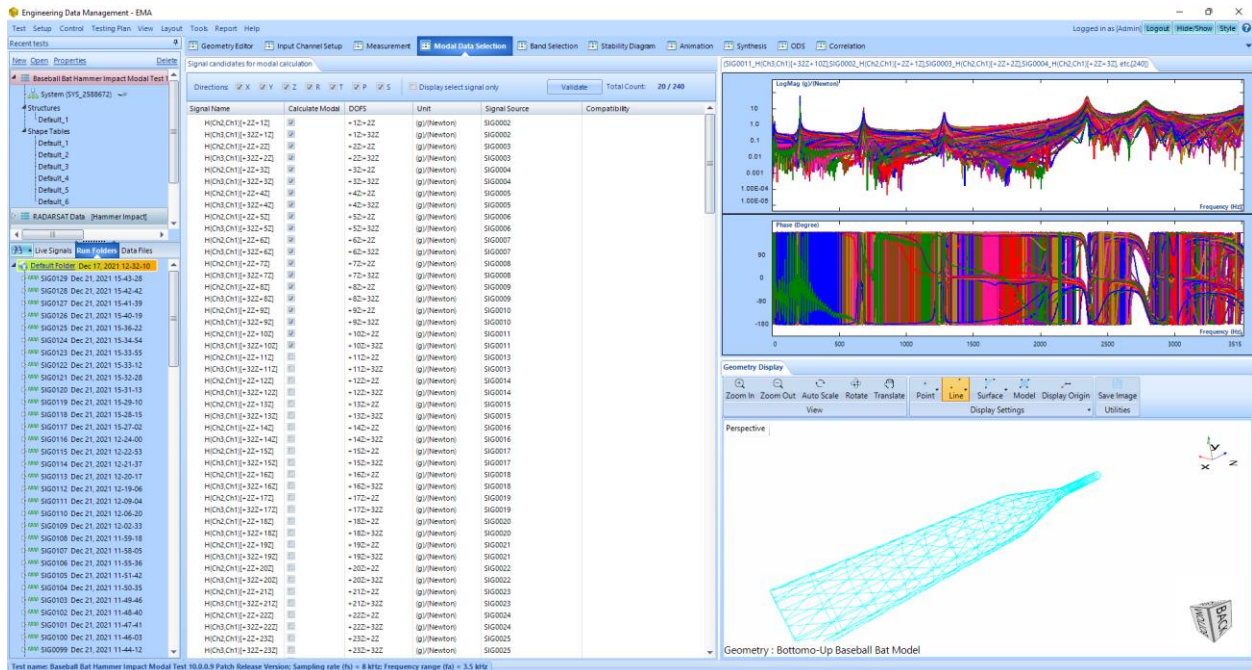

Modal Analysis of Processing Equipment

Another customer in South Africa is using Crystal Instruments' CoCo-80X and EDM Modal to measure the resonances of their mineral processing machinery.

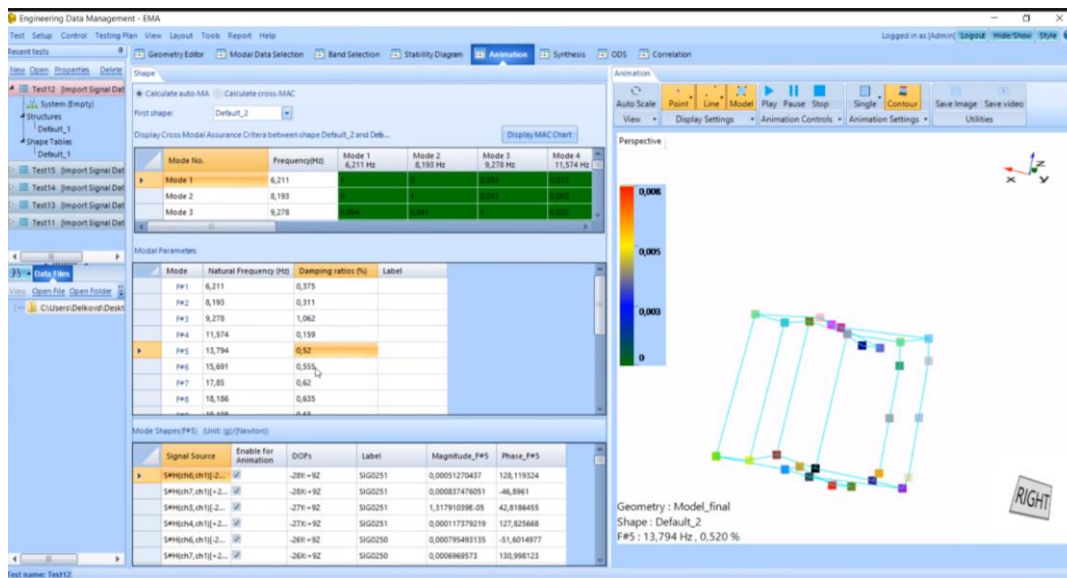

Modal Analysis of Road Pavements

An overseas customer is using CoCo-80X and EDM Modal to measure the resonances of their road pavements.

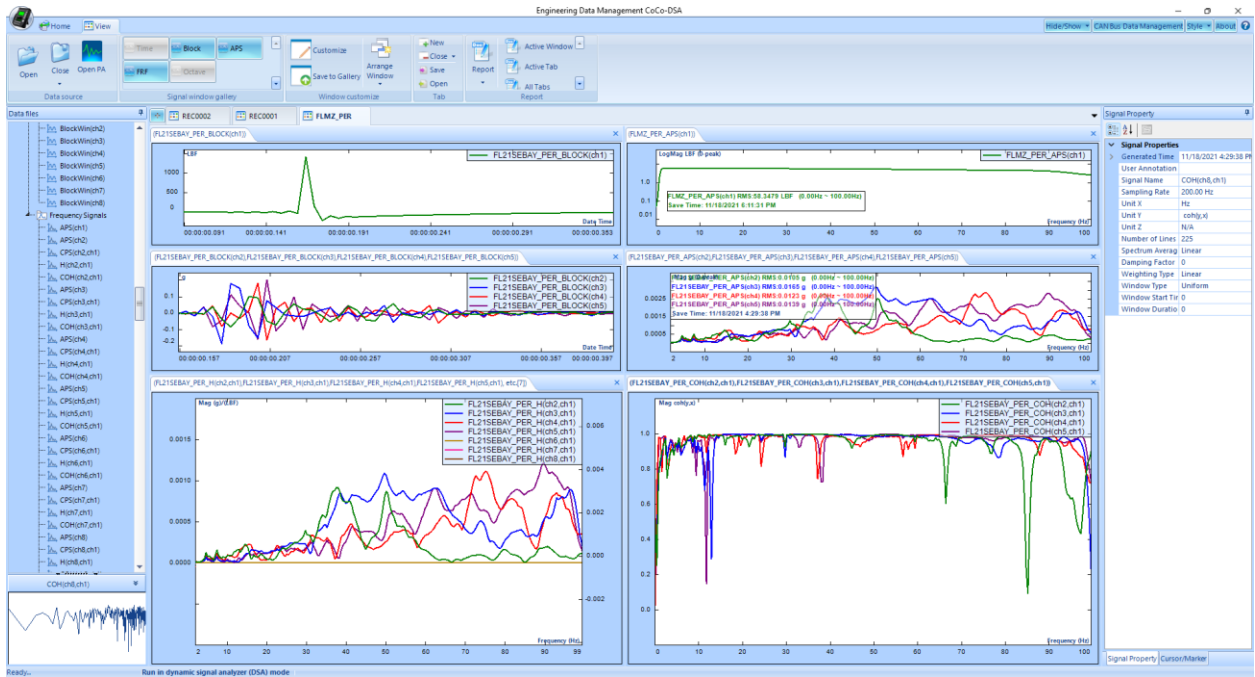
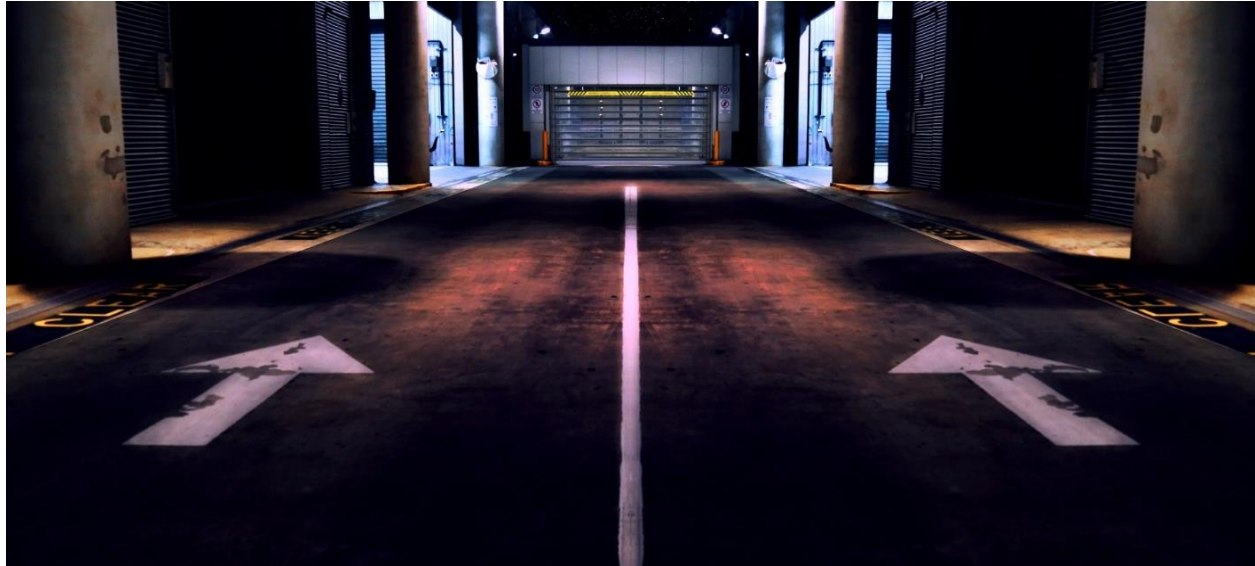

Modal Analysis of Rain Drop Sensor Assembly

A bay area customer in California is using Crystal Instruments' Modal solution package for acquiring the FRFs of their rain drop sensor dome assembly.

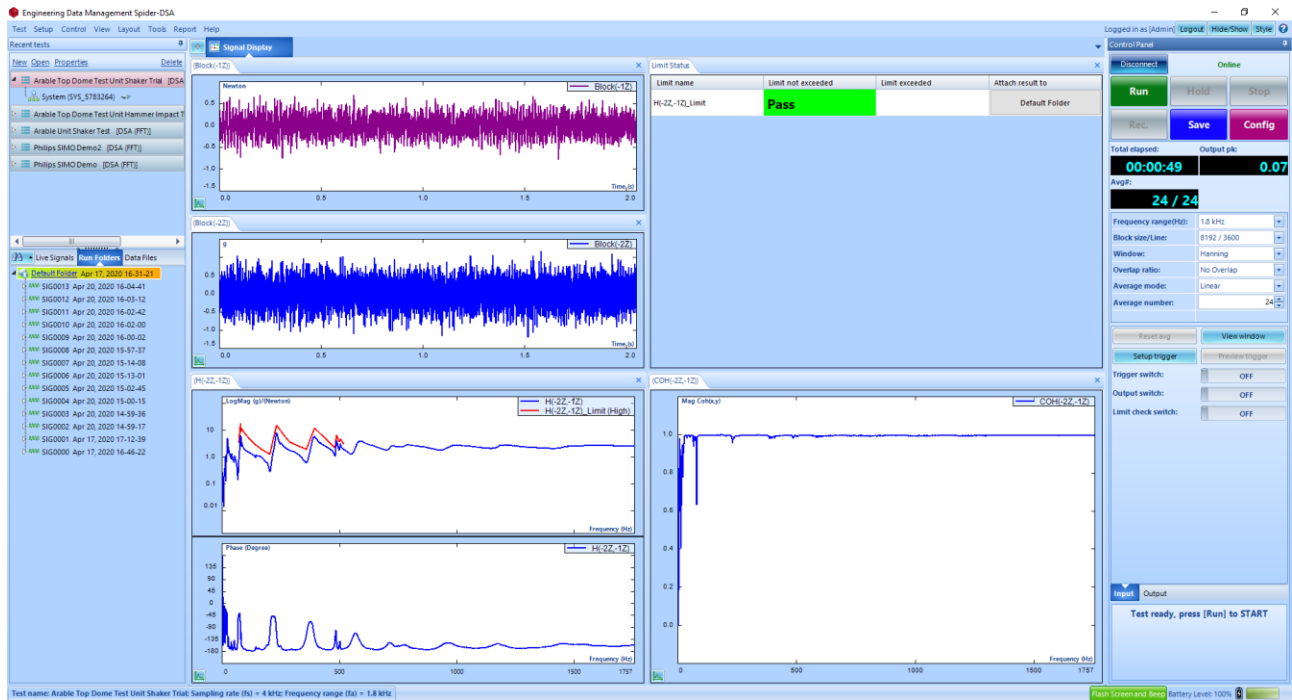

Modal Analysis of Academic Structures in Universities

Crystal Instruments works with various universities for their research projects in the field of modal analysis.

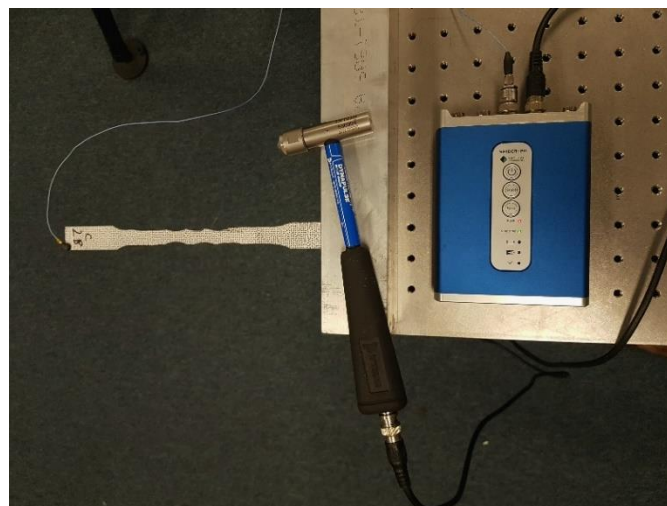
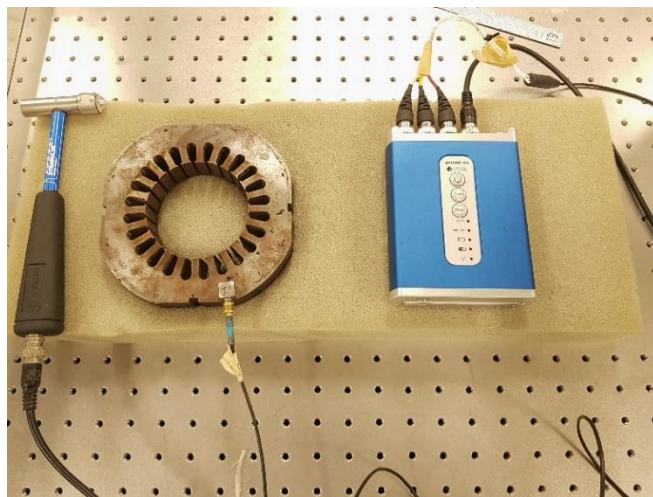

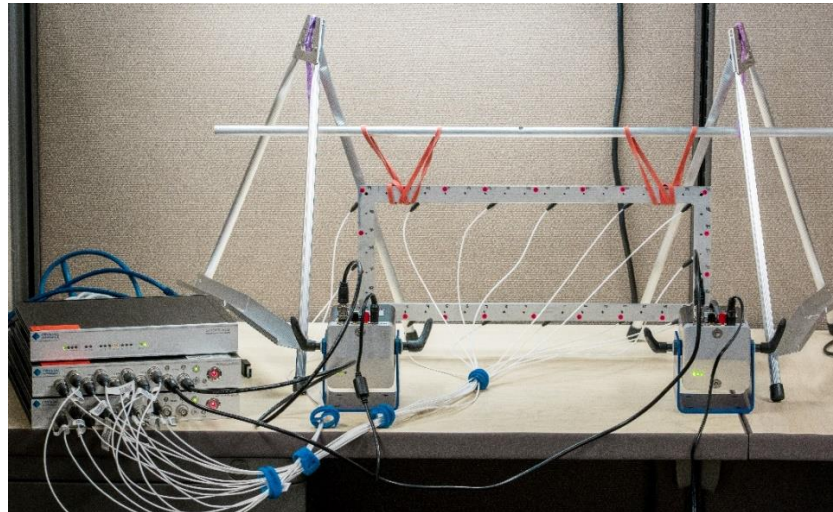
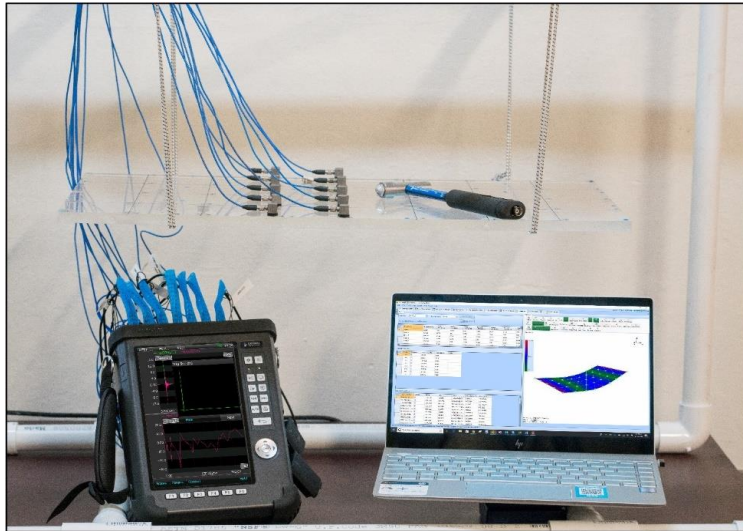

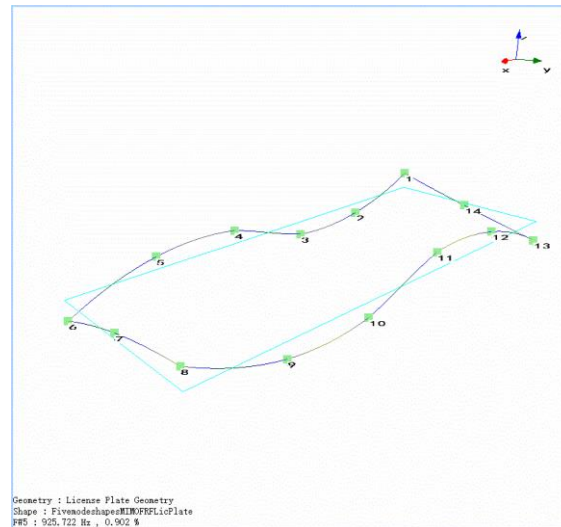
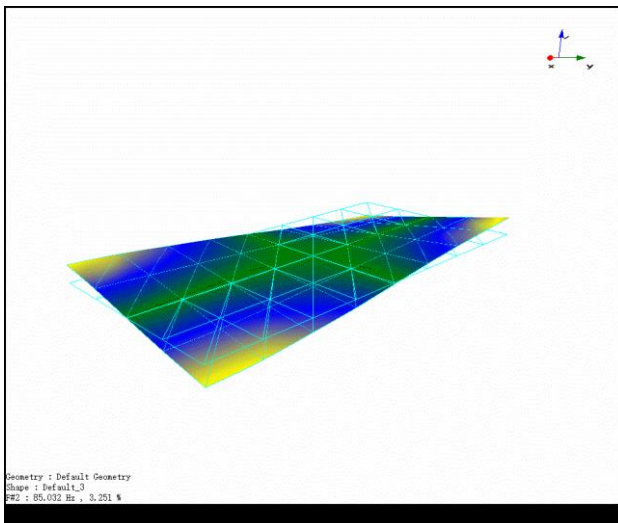
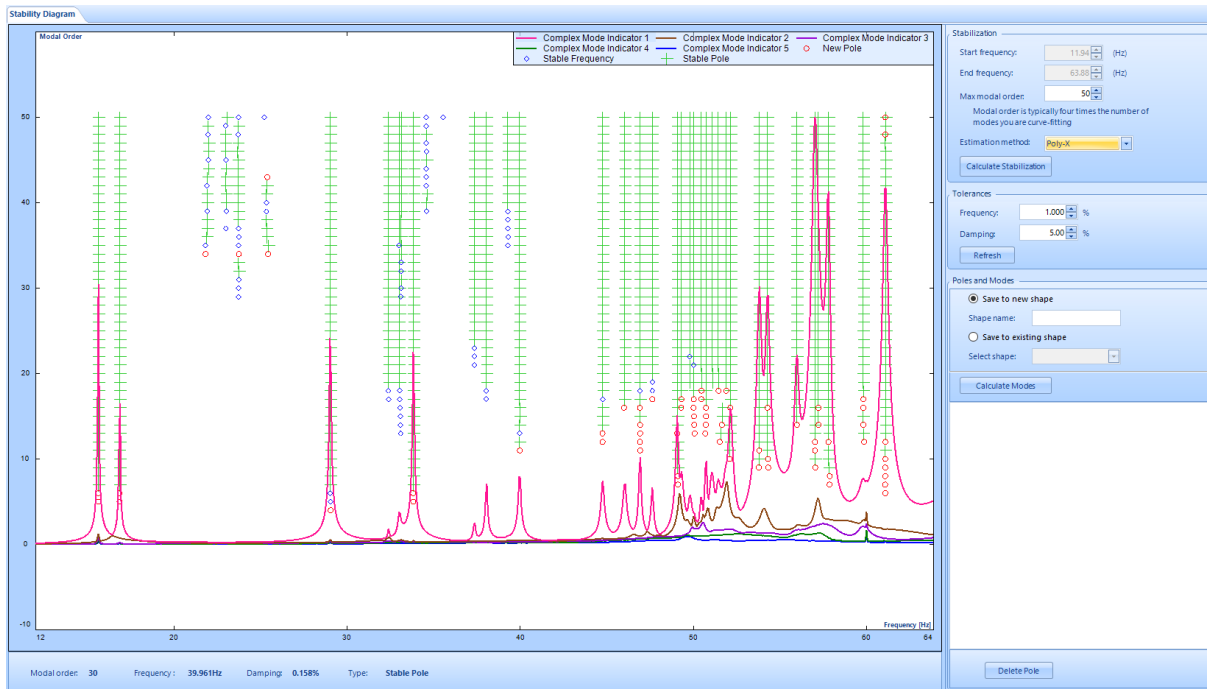

Some of the interesting cases illustrated here demonstrate the practical use and application of modal testing and analysis on various industrial and academic structures. The results emphasize the strength, simplicity, and efficiency of EDM Modal to execute sophisticated modal tests on intricate and complex structures.